

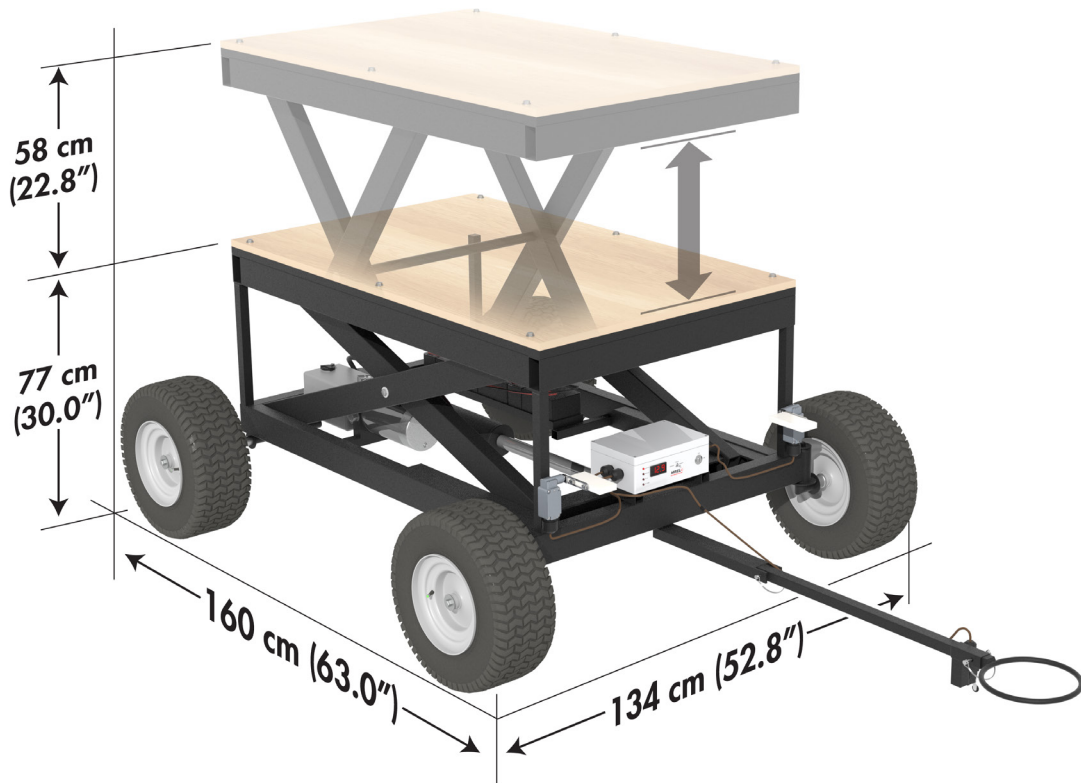

EZLIFT™ 1000 TACTICAL CART PRODUCT #: 2-72-06



DESCRIPTION:

EZLIFT™ 1000 TACTICAL CART is a rapidly deployable, 1000 kg (2200 lb.) capacity, mobile, universal lifting platform for delivering payloads either manually or remotely by robot.

APPLICATIONS*:

A wide variety of tactical operations including delivery, search, rescue and recovery are supported by **EZLIFT™ 1000 TACTICAL CART**. One example is robotically delivering MREL's lines of Tactical Disrupters to IED targets and then robotically positioning the disrupters to the correct height prior to firing. Multiple **EZLIFT™ 1000 TACTICAL CARTS** can be connected together for larger targets requiring multiple disrupters. With the optional **EZLIFT™ 1000 TACTICAL CART RAMP** (P/N 2-72-07) a robot can be delivered on the cart and disembark using the ramp at height to perform tasks that are at elevations that cannot normally be reached. With the optional **EZLIFT™ MINI ROV TRAILER** (P/N 2-72-08) a small robot can be delivered behind the cart thus extending its full operational battery life to the task as opposed to expending battery life on travel.

FEATURES:

Strong tubular steel framed electric hydraulic lift with wooden deck for ease of Operator customization to suit tasks. Reliable disc brakes which automatically engage when handle touches ground. Redundant raise/lower levers at two locations for ease of accessibility. Levers can be set by Operator up = raise and down = lower, or down = raise and up = lower. Front mounted high visibility control box with key lock, digital display of battery status and operating status LEDs. Rechargeable batteries with universal tendering system. Two sizes of ring handles for robot compatibility and one trailer hitch adapter for connecting carts together.

* Due to the sensitive nature of proven tactics, techniques and procedures (TTPs) for utilizing MREL's Tactical Disrupters to successfully disrupt improvised explosive device threats; only general descriptions of APPLICATIONS are provided in this document. Contact MREL to describe your threats and MREL will suggest the appropriate Tactical Disrupters and TTPs to assist you.



PARTS INCLUDED:

	PART #	QTY	NAME
A	2-72-06-A	1	SHIPPING CONTAINER - EZLIFT™ 1000
B	2-72-06-B	4	SHIPPING TIE DOWN STRAP - EZLIFT™ 1000
C	2-72-06-C	1	EZLIFT™ 1000 CART
D	2-72-06-D	1	CHARGER - EZLIFT™ 1000
E	2-72-06-E	1	CHARGER ADAPTER EUROPE - EZLIFT™ 1000
F	2-72-06-F	1	OPS GUIDE - EZLIFT™ 1000
G	2-72-06-G	1	DATA SHEET - EZLIFT™ 1000
H	2-72-06-H	1	TANDEM HANDLE - EZLIFT™ 1000
I	2-72-06-I	1	SMALL RING HANDLE - EZLIFT™ 1000
J	2-72-06-J	1	LARGE RING HANDLE - EZLIFT™ 1000
K	2-72-06-K	1	HANDLE EXTENSION - EZLIFT™ 1000
L	2-72-06-L	2	HITCH PIN - EZLIFT™ 1000

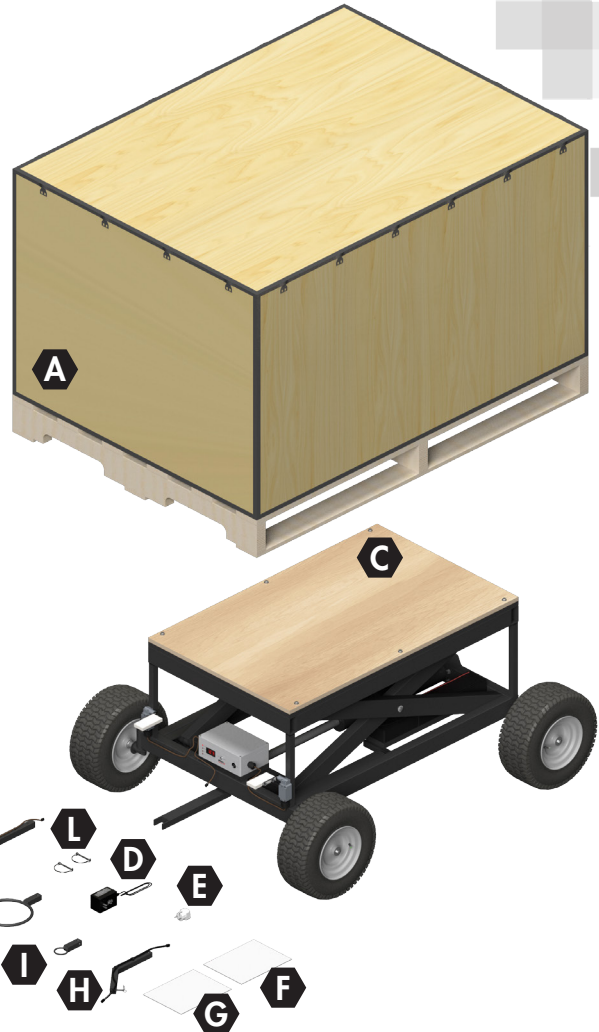

EZLIFT™ 1000 TACTICAL CART PROPERTIES:

Weight	187 kg (412 lb.)
Maximum Payload Capacity	1000 kg (2200 lb.)
Platform Dimensions (Length x Width)	127 x 80 cm (50.0 x 31.5 in.)
Minimum Height when Fully Lowered	77 cm (30.0 in.)
Maximum Height when Fully Raised	135 cm (53.0 in.)
Handles Supplied	Large 21 cm (8.5 in.) internal diameter ring handle. Small 5 cm (2.5 in.) internal diameter ring handle. Trailer hitch adapter for connecting multiple carts.
Control Box	Key lock operation. Digital display of battery status. Paddle direction switch. LED indicators: Power On, Brake On, Lift Up, Lift Down.
Control Levers	Two control levers mounted on opposite sides of cart. Raise/lower polarity is Operator settable.
Brakes	Two 15.2 cm (6.0 in.) diameter electronically activated disc brakes that automatically engage when handle touches the ground.
Power Source	3 rechargeable 12 VDC, 12 Ah sealed absorbent glass material lead acid batteries.
Battery Tender/Charger	800 mA universal smart charger with CE approval and automatic three stage charging control. 100-240 VAC, 50-60 Hz worldwide power supported